

vtech[®]

Instruction Manual

Marble Rush[®] Magnetic Dino Adventure

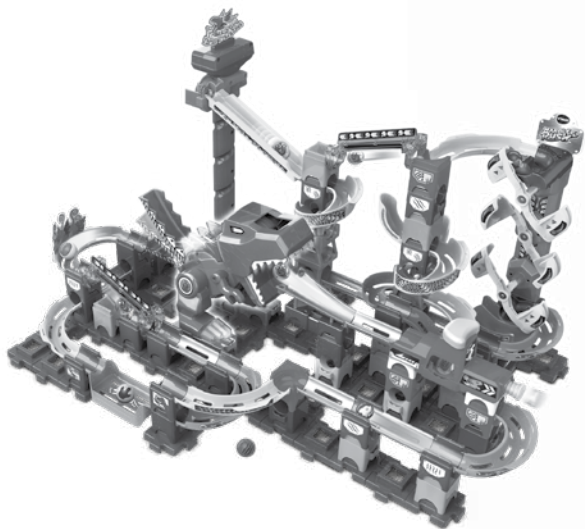

INTRODUCTION

Thank you for purchasing the **Marble Rush® Magnetic Dino Adventure**. Get ready for a rush of non-stop action! Build thrilling courses, send the marbles into motion and compete with family and friends through exciting challenges complete with lights and sounds. Please refer to the Colour Manual for detailed assembly steps.

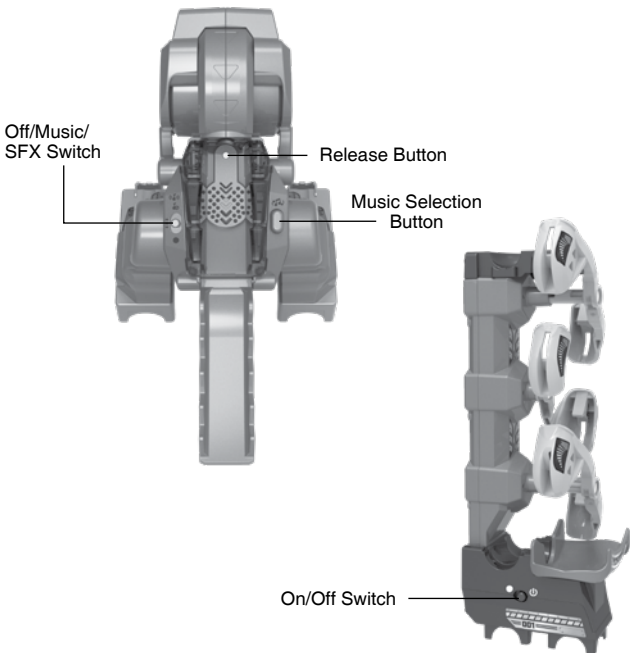

INCLUDED IN THE PACKAGE

- **Marble Rush® Magnetic Dino Adventure**
- 109 Building Pieces
- 5 Mega Marbles (metal core)
- 5 Marbles
- Sticker Sheet
- Colour Manual
- Quick Start Guide

WARNING:

All packing materials such as tape, plastic sheets, packaging locks, removable tags, cable ties, cords and packaging screws are not part of this toy and should be discarded for your child's safety.

NOTE: Please save this Instruction Manual as it contains important information.

Warning!

Not suitable for children under 36 months. Small parts and small balls. Choking hazards.

WARNING:

Do not aim at eyes or face.

WARNING:

Do not discharge any object other than the projectile provided with this toy.

NOTE

If dust appears on the pole of the rotating tower during game play, please wipe it clean with a damp cloth. Otherwise, dust will affect the ability of the product to function.

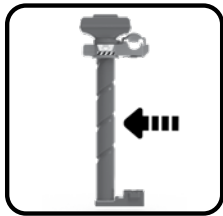

INSTRUCTIONS

T-Rex Battery Removal and Installation

1. Make sure the T-Rex is turned **Off**.
2. Find the battery cover located on the bottom of the T-Rex, use a screwdriver to loosen the screw and then open the battery cover.
3. If present, remove old batteries by pulling up on one end of each battery.
4. Install 2 new AA (LR6/AM-3) batteries following the diagram inside the battery box. (For best performance, alkaline batteries or fully charged Ni-MH rechargeable batteries are recommended).
5. Replace the battery cover and tighten the screw to secure.

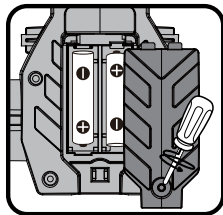

Lift Battery Removal and Installation

1. Make sure the Lift is turned **Off**.
2. Find the battery cover located on the back of the Lift, use a screwdriver to loosen the screw and then open the battery cover.
3. If present, remove old batteries by pulling up on one end of each battery.
4. Install 3 new AAA (LR03/AM-4) batteries following the diagram inside the battery box. (For best performance, alkaline batteries or fully charged Ni-MH rechargeable batteries are recommended).
5. Replace the battery cover and tighten the screw to secure.

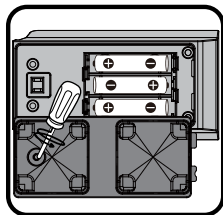

WARNING:

Adult assembly required for battery installation.
Keep batteries out of reach of children.

IMPORTANT: BATTERY INFORMATION

- Insert batteries with the correct polarity (+ and -).
- Do not mix old and new batteries.
- Do not mix alkaline, standard (carbon-zinc) or rechargeable batteries.
- Only batteries of the same or equivalent type as recommended are to be used.
- Do not short-circuit the supply terminals.
- Remove batteries during long periods of non-use.
- Remove exhausted batteries from the toy.
- Dispose of batteries safely. Do not dispose of batteries in fire.

RECHARGEABLE BATTERIES

- Remove rechargeable batteries (if removable) from toy before charging.
- Rechargeable batteries are only to be charged under adult supervision.
- Do not charge non-rechargeable batteries.

Disposal of batteries and product



The crossed-out wheellie bin symbols on products and batteries, or on their respective packaging, indicates they must not be disposed of in domestic waste as they contain substances that can be damaging to the environment and human health.



The chemical symbols Hg, Cd or Pb, where marked, indicate that the battery contains more than the specified value of mercury (Hg), cadmium (Cd) or lead (Pb) set out in the Batteries and Accumulators Regulation.

The solid bar indicates that the product was placed on the market after 13th August, 2005.

 Please dispose of your product and batteries responsibly.

In the UK, give this toy a second life by disposing of it at a small electricals collection point* so all of its materials can be recycled.

Learn more at:

www.vtech.co.uk/recycle

www.vtech.com.au/sustainability

* Visit www.recyclenow.com to see a list of collection points near you.

ASSEMBLY INSTRUCTIONS

Adult assembly required. For your child's safety, do not let your child play with this product until it is fully assembled.

1. Align the dinosaur's legs with the buckle as shown in the below picture and snap them in.

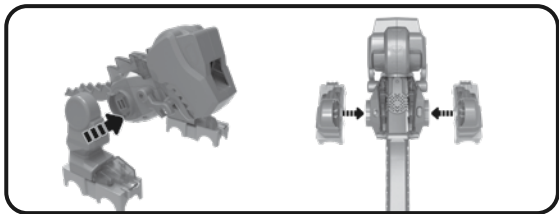

2. If the buckles are separated, please reattach them with the following steps. Align both ends of the transparent magnetic cable with the two buckles and snap them in place. A snapping sound will indicate they are connected.

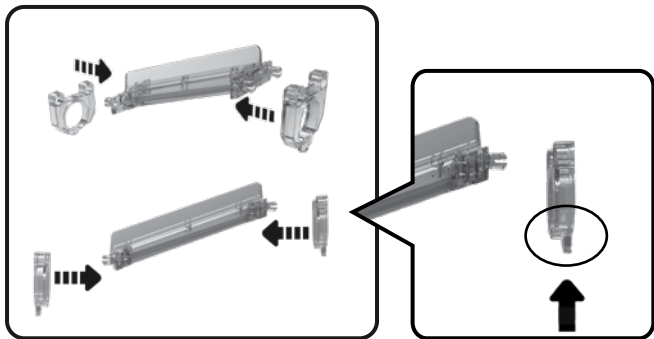

Note: Please make sure the direction of the buckles are correct before snapping.

LABEL APPLICATION

Please securely stick the labels to the play set as indicated below:



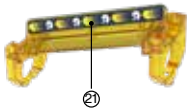
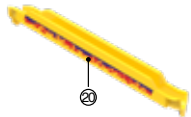
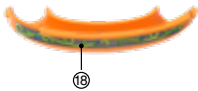
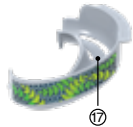
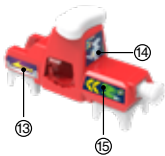
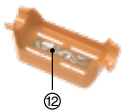
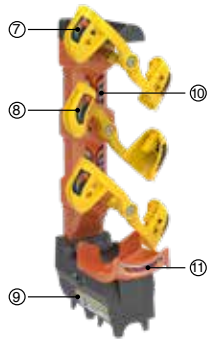
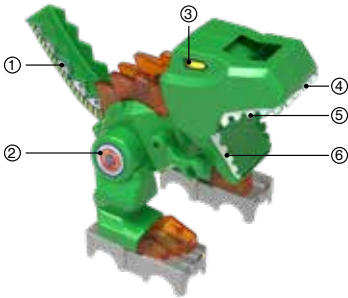

PRODUCT FEATURES

1. Off/Music/SFX Switch ● 🎵 🎶

Slide the switch all the way to 🎶 to turn on both music and sound effects (SFX). The middle position 🎵 plays SFX with no background music. Slide the switch all the way to ● to turn off the **T-Rex**.



2. Music Selection Button 🎶

Press the **Music Selection Button** to cycle through the background music options.

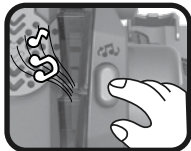

3. Release Button

You may press this button to release the marbles stored inside the Dino's tail.



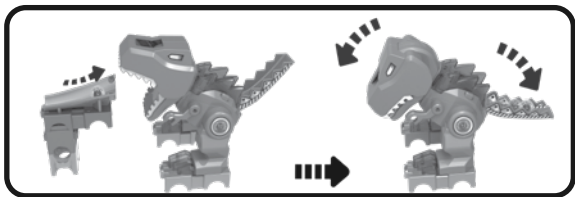

4. Chomping T-Rex & Marbles

When Mega Marbles go into the Chomping T-Rex's mouth and are detected by the magnetic trigger, the Chomping T-Rex's mouth will snap and its body will straighten while playing a dino sound effect. At the same time, the tail will roll down.



5. Automatic Shut-Off

To preserve battery life, the **Marble Rush® Magnetic Dino Adventure** will automatically power-down after several minutes without input. The Chomping T-Rex can be turned on again by sliding the **Off/Music/SFX Switch** to  or . The T-Rex will automatically turn off when battery power is too low.

CARE & MAINTENANCE

1. Keep the unit clean by wiping it with a slightly damp cloth.
2. Keep the unit out of direct sunlight and away from any direct heat sources.
3. Remove the batteries if the unit will not be in use for an extended period of time.
4. Do not drop the unit on hard surfaces and do not expose the unit to moisture or water.
5. If the unit stops working or malfunctions, install a new set of batteries.

TROUBLESHOOTING

If for some reason the unit stops working or malfunctions, please follow these steps:

1. Turn the unit Off.
2. Interrupt the power supply by removing the batteries.
3. Let the unit stand for a few minutes, then replace the batteries.
4. Turn the unit back On. The unit should now be ready to use again.
5. If the unit still does not work, install a brand new set of batteries.

CONSUMER SERVICES

Creating and developing **VTech®** products is accompanied by a responsibility that we at **VTech®** take very seriously. We make every effort to ensure the accuracy of the information, which forms the value of our products. However, errors sometimes can occur. It is important for you to know that we stand behind our products and encourage you to call our Consumer Services Department with any problems and/or suggestions that you might have. A service representative will be happy to help you.

UK Customers:

Phone: 0330 678 0149 (from UK) or +44 330 678 0149 (outside UK)

Website: www.vtech.co.uk/support

Australian Customers:

Phone: 1800 862 155

Website: support.vtech.com.au

NZ Customers:

Phone: 0800 400 785

Website: support.vtech.com.au

PRODUCT WARRANTY/ CONSUMER GUARANTEES

UK Customers:

Read our complete warranty policy online at vtech.co.uk/warranty.

Australian Customers:

VTECH ELECTRONICS (AUSTRALIA) PTY LIMITED –
CONSUMER GUARANTEES

Under the Australian Consumer Law, a number of consumer guarantees apply to goods and services supplied by VTech Electronics (Australia) Pty Limited. Please refer to vtech.com.au/consumerguarantees for further information.

**Visit our website for more
information about our products,
downloads, resources and more.**

www.vtech.co.uk
www.vtech.com.au

